

American DJ **AUDIO**

DCD-PRO300
DUAL CD PLAYER



PROformer plus

IMPORTANT SAFETY ITEMS FOR U.S.A. & CANADA MODEL ONLY

WARNING:

TO PREVENT FIRE OR SHOCK HAZARD, DO NOT EXPOSE THIS CD PLAYER TO WATER OR MOISTURE.

CAUTION:

1. Handle the power supply cord carefully. Do not damage or deform; it may cause electric shock or malfunction when used. Hold plug attachment when removing from wall outlet. Do not pull on the cord.
2. To avoid electric shock, do not open the top cover when the unit is plugged in. If problems occur with the unit, call your local American DJ AUDIO dealer.
3. Do not place metal objects or spill liquid inside the CD player. Electric shock or malfunction may occur.

Please record and retain the model name and serial number from your rating label.

Model No. _____

Serial No. _____

NOTE:

This CD player uses a semiconductor laser. It is recommended for use in a room at the following temperature: 41°F - 95°F / 5°C - 35°C

CAUTION

TO PREVENT ELECTRIC SHOCK DO NOT USE THIS (POLARIZED) PLUG WITH AN EXTENSION CORD, RECEPTACLE OR OTHER OUTLET UNLESS THE BLADES CAN BE CAREFULLY INSERTED TO PREVENT BLADE EXPOSURE.

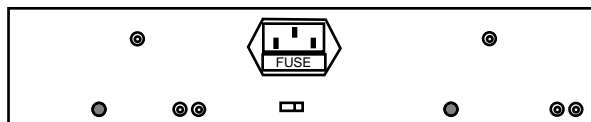

CAUTION:

USE OF CONTROLS OR ADJUSTMENTS OTHER THAN THOSE SPECIFIED HEREIN MAY RESULT IN HAZARDOUS RADIATION EXPOSURE.

THE COMPACT DISC PLAYER SHOULD NOT BE ADJUSTED OR REPAIRED BY ANYONE EXCEPT PROPERLY QUALIFIED SERVICE PERSONNEL.



CAUTION
Do not open - risk of electric shock



CAUTION: TO REDUCE THE RISK OF ELECTRIC SHOCK, DO NOT REMOVE THE COVER RACK. THERE ARE NO USER SERVICEABLE PARTS INSIDE. REFER SERVICE TO YOUR AUTHORIZED AMERICAN DJ AUDIO DEALER.



The lightning flash with an arrow triangular symbol is intended to alert the user to the presence of uninsulated "dangerous voltage" within the products enclosure, and may be of sufficient magnitude to constitute a risk of electric shock.



The exclamation point triangular symbol is intended to alert the user to the presence of important operating and maintenance (servicing) instructions in the user manual accompanying the CD player.

NOTE:

This unit may cause interference to radio and television reception.

Line Voltage Selection
(for multiple voltage model only)



- The desired voltage may be set with the VOLTAGE SELECTOR switch on the rear panel (using a screwdriver).
- Do not twist the VOLTAGE SELECTOR switch with excessive force as this may cause damage.
- If the VOLTAGE SELECTOR switch does not move smoothly, please contact a qualified service technician.

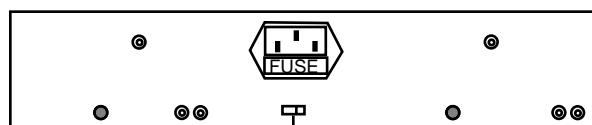

VOLTAGE SELECTOR switch

SAFETY INSTRUCTIONS

1. Read Instructions - All the safety and operating instructions should be read before the appliance is operated.
2. Save Instructions - The safety and operating instructions should be saved for future reference.
3. Heed Warnings - All warnings on the appliance and in the operating instructions should be adhered to.
4. Follow Instructions - All operating and user instructions should be followed.
5. Water and Moisture - The appliance should not be used near water - for example, near a bath tub, washbowl, kitchen sink, laundry tub, in a wet basement or near a swimming pool, etc.
6. Ventilation - The appliance should be situated so that its location or position does not interfere with its proper ventilation. For example, the appliance should not be situated on a bed, sofa, rug, or similar surface that may block the ventilation openings; or, placed in a built-in installation, such as a bookcase or cabinet that may impede the flow of air through the ventilation openings.
7. Heat - The appliance should be situated away from heat sources such as radiators, heat registers, stoves, or other appliances (including amplifiers) that produce heat.
8. Power Sources - The appliance should be connected to a power supply only of the type described in the operating instructions or as marked on the appliance.
9. Grounding or Polarization - Precautions should be taken so that the grounding or polarization means of an appliance is not defeated.
10. Power-Cord Protection - Power-supply cords should be routed so that they are not likely to be walked on or pinched by items placed upon or against them, paying particular attention to cords at plugs, convenience receptacles, and the point where they exit from the appliance.
11. Cleaning - The appliance should be cleaned only as recommended by the manufacturer.
12. Non-use Periods - The power cord of the appliance should be unplugged from the outlet when left unused for a long period of time.
13. Object and Liquid Entry - Care should be taken so that objects do not fall and liquids are not spilled into the enclosure through openings.
14. Damage Requiring Service - The appliance should be serviced by qualified service personnel when:
 - A. The power-supply cord or the plug has been damaged.
 - B. Objects have fallen, or liquid has been spilled into the appliance.
 - C. The appliance has been exposed to rain or water.
 - D. The appliance does not appear to operate normally or exhibits a marked change in performance.
 - E. The appliance has been dropped, or the enclosure damaged.
15. Servicing - The user should not attempt to service the appliance beyond that described in the operating instructions. All other servicing should be referred to qualified service personnel.

PREPARATIONS

1. Checking the Contents

Check that the carton contains the following items:

- 1) Main unit
- 2) Control unit
- 3) Operating instructions (this booklet)
- 4) Two sets of RCA cables.
- 5) Two Control cords (6 feet / 1.8 meters)

2. Installing the Units

Mount the units onto your console or rack with 19" EIA rack rails.

CAUTION:

- The player will work normally when the main unit is mounted with the front panel within 15 degrees of the vertical plane. If the unit is tilted excessively, discs may not be loaded or unloaded properly. (**Figure 1**)
- The control panel's LCDs are designed to be clearly visible within the angles shown in **Figure 2**. Mount the control unit so that the visual angle is within this range.

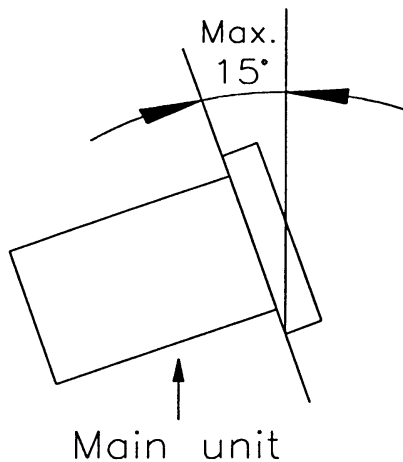

Fig. 1

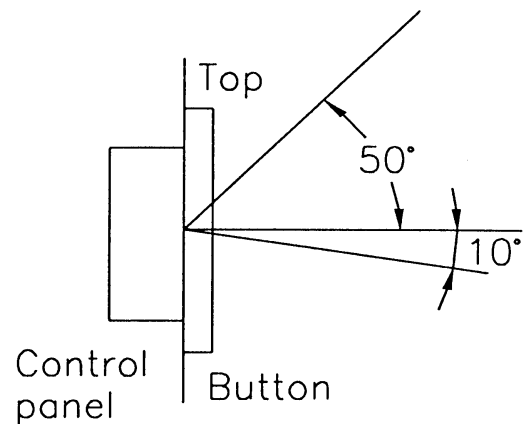

Fig. 2

3. Connections

- 1) Turn off the POWER switch.
- 2) Connect the RCA pin cables to the inputs on your mixer.
- 3) Connect the control cables to the REMOTE connector on the main unit.

CAUTION:

Be sure to use the supplied control cables. Using another type of cable may result in damage.
Be sure the power is off when connecting the control cables. Otherwise the units may not work properly.

GENERAL NOTES ON USE

- Avoid high temperatures.
Allow for sufficient heat dispersion when installed on a rack.
- Handle the power cord carefully.
- Hold the plug when unplugging the cord.
- Keep the set free from moisture, water, and dust.
- Unplug the power cord when not using the set for long periods of time.
- Do not obstruct the ventilation holes. (For sets with ventilation holes.)
- Do not let foreign objects in the set.
- Do not let insecticides, benzene, and thinner come in contact with the set.
- Never disassemble or modify the set in any way.

MAIN FEATURES

- (1) 8 times over sampling 1 bit D/A converter
 - (2) Beat counter
 - (3) Auto cue
 - (4) Frame search
 - (5) Realtime cue
 - (6) 4 different speed scan
 - (7) Pitch display
 - (8) 10 number buttons for direct track access
 - (9) 30 programmable tracks
 - (10) Ten cue points can be memorized
 - (11) Digital output RCA coaxial
 - (12) Fader Start , Fader Stop , (back cue) Relay playback (using the control jack)*
 - (13) Large brite LCD Screen can be viewed from wide angles.
 - (14) Transport protection
- * **Must have a Mixer equipped with the signal output. Look for this feature in Future American DJ Mixers.**

GENERAL FEATURES (Cont.)

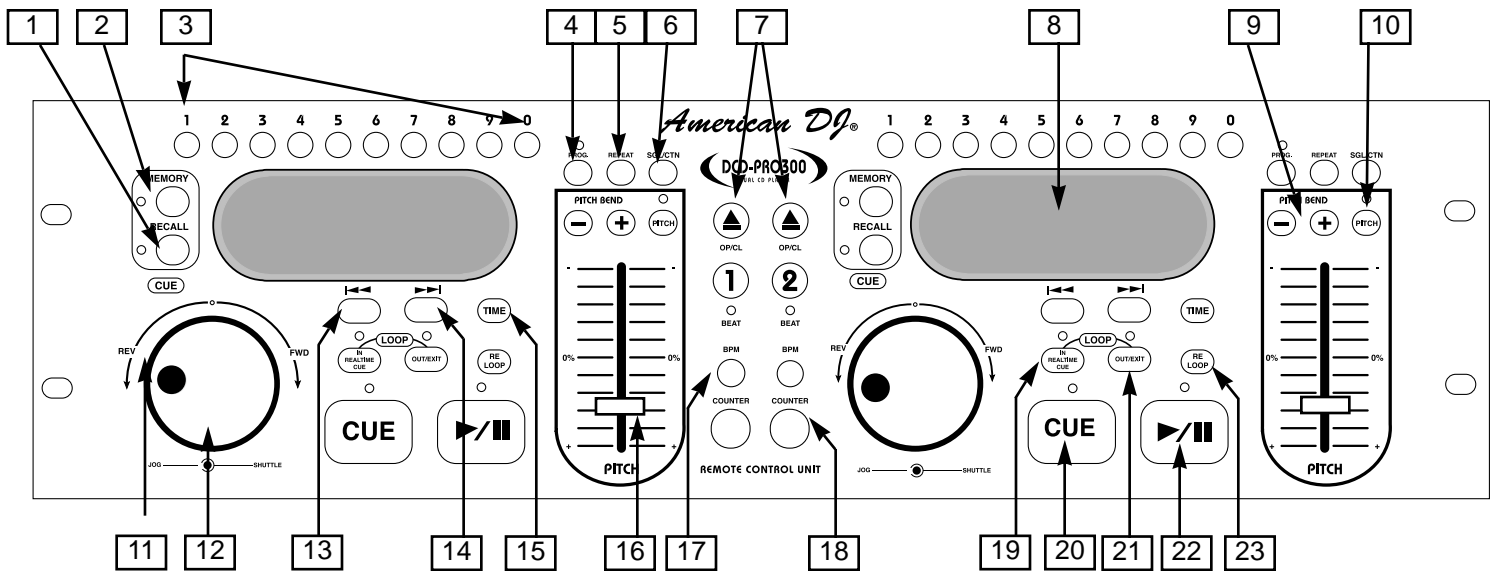

A. REMOTE UNIT FRONT

1. **RECALL** This button allow you to cue up any of the 10 memory points that have been memorized. Press **RECALL** button then any of the 10 number buttons. the player will cue up the selected point and pause.
2. **MEMORY** This button allows you to program up to 10 points on the CD. Press the **MEMORY** button during play or pause, the memory LED lights up. Use frame search to reach desired point, then press a number button to memorize that starting point. Repeat above steps to memorize all 10 starting points if desired.
3. **NUMBER** buttons (1 to 10) These buttons are used to select a particular track number starting point. They are also used in **MEMORY** and **RECALL** modes.
4. **PROGRAM-** Depress this button to stop the CD and enter the program mode. Note the word "PROGRAM" is indicated on the display. Select each track to be programmed with the f. skip and b.skip buttons (13 & 14). and press the PROGRAM button between selections. You can program up to 30 tracks. Press PLAY to start the program. To exit and erase program hold the program button down for more than 2 seconds while the unit is stopped, open the disc tray, or turn off the power.
5. **REPEAT** This button allows you to select between
REPEAT 1
REPEAT ALL CONTINUOUS PLAY
6. **SGL/CTN** You can choose between a single track to play or all tracks in order by pressing once or twice.
7. **OPEN/CLOSE** (Disc Tray Open/Close)- Press to load or eject the disc. Each press will open or close the disc tray on the transport. NOTE: Tray will not open unless the disc has been paused.

8. **LCD DISPLAY-** Indicates all the functions, as they are occurring, with the CD. These functions are explained in the next section.

9. **PITCH BEND +/- 16%** (Pitch Bend Button)-When each of the two CD players is playing a CD, the pitch bend function allows the positioning of the bass beats to be matched after the pitch of each disc is matched. Either player can "catch up" or "fall back" to match the other player. The pitch will automatically rise while the + button is pressed (allowing "catch up") and return to the original pitch when the button is released. The pitch will automatically drop while the - button is pressed (allowing "fall back") and return to the original pitch when the button is released. By changing the pitch of one disc with respect to the other in this way the beats can be matched.

10. **PITCH** (Pitch Button)- This button activates the Pitch Slider (14).

11. **SHUTTLE WHEEL** (OUTER RING)- This wheel has 4 forward and 4 reverse speed positions for searching through songs. The more you turn the wheel in either direction the faster you search through the music.

12. **JOG WHEEL** (INNER RING)- This jog wheel serves 2 functions depending on the mode you are working in.

a. The jog wheel will act as a slow frame search control when the CD is not playing but either paused or set to a cue point. To set a new frame cue point, spin the wheel then press play when you have determined the proper position. Press CUE to return to the "CUE POINT".

GENERAL FEATURES (Cont.)

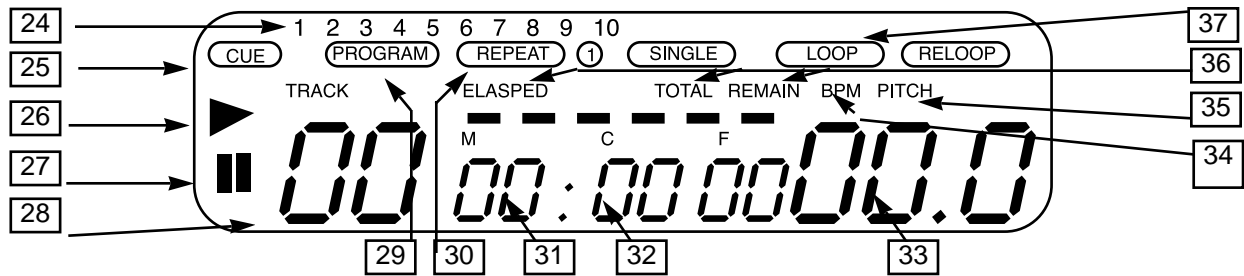

13 & 14 TRACK (Track Buttons)- These buttons are used to select the track to be played. Forward skip & Back skip.

15. TIME (Time Button)- The TIME button switches between Elapsed playing time, Remaining time in a selection, Total remaining time of the disc.

16. PITCH SLIDER- The pitch can be changed up to +/-12% by pressing the PITCH button so the PITCH LED is lit, then moving the sliding fader. The pitch will not be changed if the PITCH LED is off.

17. BPM BUTTON- Switches the mode of the display between showing the BPM and the percentage change in pitch. Use COUNTER button.

18. COUNTER BUTTON- Tap this button with the beat of the music to determine the current Beats Per Minute (BPM).

19. REAL TIME CUE -This allows you to set the cue point without stopping the play back This button also set the beginning of a loop

20. CUE- Pressing the CUE button during play provides a return to the position at which play was started. If PAUSE is used before CUE or CUE point was set, that will become the cue point. Alternately pressing the PLAY button and the CUE button allows the CD to be played from the same position any number of times. The CUE LED will light up from the time the Cue button is pressed until the CD has reset to the position at which play was started. Steady lighting of this LED indicates the ready condition.

21. OUT / EXIT- Used to set the ending when looping music. The player will start to loop continuous until you press this button again to exit. This is not a seamless function.

22. START/PAUSE (Play/Pause Button)- Each press of the Play/Pause Button causes the operation to change from play to pause or from pause to play.

23. RELOOP BUTTON- If a loop has been made and you have hit the exit button, press this button to enter the loop again. to exit loop press OUT/EXIT button

B. LCD

26. PLAY Indicators (▶) - The PLAY indicators light during playback.

27. PAUSE Indicators (||) - The PAUSE indicators light during pause or cue mode.

28. A-B Indicators - These light when player performs repeat A-B playback.

29. PROGRAM Indicator - This lights when program mode is set or played.

30. REPEAT Indicators - (REPEAT 1, REPEAT ALL) These light during repeat one or all playback.

28,31,32 TRACK, MINUTE, SECOND

These displays indicate information on the current track and time.

33. PITCH OR BPM DISPLAY- Show either beat per minute or percent of pitch adjustment.

34. BPM INDICATOR - lights up when BPM Button is engaged

35. PITCH INDICATOR- light to show percent of pitch is displayed.

36. ELAPSED, TOTAL REMAIN Indicators - These indicate that the time shown on the display is the ELAPSED, TOTAL REMAINING or single song remaining time.

37. LOOP , RELOOP - displayed when loop is engaged loop flashes when playing loop.

D. Main Unit Rear Panel

LINE OUT 1 and 2 - The audio signals from each player are output from these jacks.

REMOTE - Connect this connector to the control unit using the included control cords.

DIGITAL - connect to Minidisc or CDR device.

Voltage Selector - (multi-voltage models only) On multi-voltage models, use this to select the power voltage. Always disconnect the power plug before changing the voltage.

E. Control Unit Rear Panel (figure 4)

Connect to main unit - Connect this connector to the REMOTE connector on the main unit using the included control cords.

Control - Connect this connector to the control out from mixer control out. Available on future mixers.

BASIC OPERATIONS

1. Opening and Closing the Disc Tray and Loading Discs

a) Opening and closing the disc tray

- This operation only works when the power is on.
- Press the OPEN/CLOSE button to open or close the disc tray. OPEN/CLOSE buttons are provided on both the main unit and control unit or
- Press PLAY button tray automatically closes
- If tray is not closed after 60 seconds it will close automatically and pause.
- The disc trays cannot be opened during playback to prevent playback from being interrupted if the OPEN/CLOSE button is pressed accidentally. Stop playback, then press the OPEN/CLOSE button.

2. Loading discs

- Hold the disc by the edges and place it in the disc tray. Do not touch the signal surface (the glossy side).
- When using 5 inch/12 cm discs, place the disc in the outer tray guides (Figure 8), and when using 3 inch/8 cm discs, place them securely in the inner guides (Figure 9).

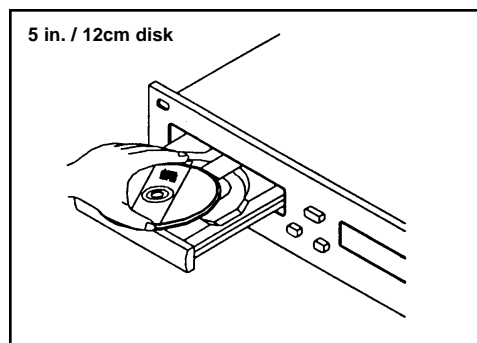

Fig. 8

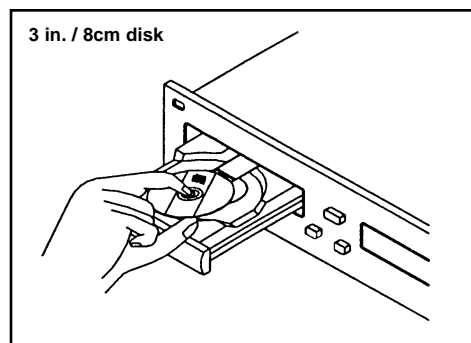

Fig. 9

CAUTION:

- Do not place any foreign objects in the disc tray, and do not place more than one disc in the disc tray at a time. Doing so may result in malfunction.
- Do not push the disc tray in manually when the power is off, as this may result in malfunction and damage the player.

3. Selecting Tracks

- Select desired track using NUMBER Button or
- Press the TRACK Buttons once to move to one higher or lower track or
- Hold the TRACK buttons in to change tracks continuously at a higher speed.
- When a new track is selected during playback, playback begins as soon as the search operation is completed.

4. Starting Playback

- Press the PLAY/PAUSE button during the pause or cue to start playback.
- The PLAY indicator lights when playback starts.
- The point at which playback starts is automatically stored in the memory as the cue point. The pickup then returns to the cue point (the point at which playback started) when the CUE button is pressed. (Back Cue)

5. Stopping Playback

- There are two ways to stop playback.
 - 1) Press the PLAY/PAUSE button during playback to pause at that point.
 - 2) Press the CUE button during playback to return to the position at which playback started.(Back Cue)

6. Pausing

- Press the PLAY/PAUSE button to switch between play and pause.
- The PAUSE indicator lights when the pause mode is set.
 - 1) The player has completed the cue or pause operation and is waiting for the play start command.
 - 2) When the PLAY/PAUSE button is pressed, playback starts and the cue point is stored in the memory.
 - 3) Playing
 - 4) The pause mode is set when the PLAY/PAUSE button is pressed again.
 - 5) Pausing
 - 6) Playback resumes when the PLAY/PAUSE button is pressed again. The new cue point is stored in the memory.
 - 7) Playing

7. Cueing

- "Cueing" is the action of preparing for playback; when the Cue button is pressed, playback returns to the cue point and enters pause mode. When the PLAY/PAUSE button is pressed during the cue mode, playback starts.
- Cue point setting:
 - A Playback starts from pause or skip to a new track during play or pause. The beginning play point will be set to the cue point.

Or
 - B Press the REALTIME CUE button during playback to set the new cue point.

Or
 - C Memorize any of 10 CUE points by pressing MEMORY then set desired Cue then press any of 10 number buttons. you can also set any of the 10 Cue points by pressing MEMORY then any of the NUMBER Buttons.

To return to Cue point press Cue Button. This will return to point A or B above.

The player has completed the cue or pause operation and is waiting for the play start command.

When the PLAY/PAUSE button is pressed, playback starts.

To Return to any of the 10 Cue points press RECALL then desired number buttons

The player has completed the cue or pause operation and is waiting for the play start command.

When the PLAY/PAUSE button is pressed, playback starts.

NOTE: When play starts via pause or track skipping or scanning, the cue point will change to the start point automatically.

8. Auto cue

When disk is loaded, the cue point is set to the first source of music.

If track is changed before pressing play , the cue point is changed to the new starting point.

If you pause during playback this also sets the new cue point.

9. Frame search

This is done by first pausing then using the jog wheel to set the starting point. (When you use the jog wheel the monitor function allows you to here what is playing. Once you have set starting point press PLAY then CUE to again mute output.)

10. Scanning (fast forward / Fast reverse)

To do this rotate Shuttle wheel forward or reverse

You will scan or reverse at 4 different speeds depending on how much you rotate the wheel.

11. Loop play

You can loop between two points continuously

Press IN REAL TIME CUE Button for starting point

Set end point by pressing OUT/ EXIT Button, CD will begin looping until OUT/ EXIT Button is pressed again.

Press ReLoop to again enter the loop.

Note: this is not a seamless function.

12. Time Display

During normal play, each time you press TIME button, the display changes to give you the following information. (Fig.14)

A = Elapsed playing time.

B = Remaining time in a selection. If the current selection number is over 34, ‘.....’ is displayed.

C = Total remaining time of the disc.

13. Repeat playback

1) Press REPEAT button, the REPEAT 1 indicator lights, the player repeats the one track selected.

2) Press REPEAT button again, the REPEAT ALL indicator lights. The player will then repeat all tracks on disc.

3) Press REPEAT button again, the repeat function is cancelled.

14. Pitch Bending

- The speed increases or decreases respectively while the PITCH BEND+ or PITCH BEND- button is pressed. The extent to which the speed changes is proportionate to the amount of time the button is pressed. For example, if the PITCH BEND+ button is held in continuously, the speed increases continuously.
- The pitch changes within a range of +/- 16%.
- The jog wheel will temporarily bend the pitch of the music if the song is already playing by rotating the wheel clockwise to speed up or counterclockwise to slow down. The speed that you rotate the JOG Wheel determines the percent of pitch bend.

15. Program Play

Press PROG. Button to make the unit enter the program mode and stop condition.

The program indicator lights. Select Track using NUMBER button press PROG. again.

Repeat this up to 30 times.

Press play Button to begin playing programmed tracks.

To cancel Program press and hold PROG. Button more than 2 sec.

MATCHING THE BEATS PER MINUTE (BPM)

1. Find the BPM of the song playing by pressing BPM button. Then tap COUNTER button firmly to the beat of the music until BPM is displayed on the LCD.
2. Repeat step 1 for the song you want to mix in. You can listen in by cueing it in your headphones using your mixer or follow the BEAT LED on the CD.
3. Engage Pitch by pressing PITCH on the side you want to use ,make sure Readout is in BPM by pressing BPM Button until BPM is lit on LCD. Adjust pitch until same BPM as original song is reached.

BEFORE SWITCHING OFF THE POWER

When you have finished using the CD player, before switching off the power be sure that the disc holder has been closed with the OPEN/CLOSE button (Figure 15).

Tray Protection: If tray is not closed after 60 seconds it will close automatically and pause.

CAUTION: Do not forcibly close the disc holder when the power is off.

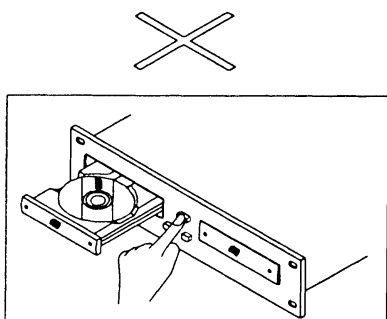

Do not switch off the power when the disc holder is open.

Fig. 15

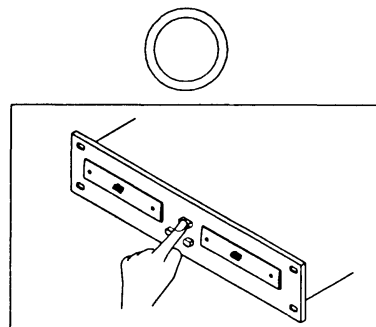

Switch off the power after the disc holder has been closed with the OPEN/CLOSE button.

COMPACT DISCS

1. Precautions on handling compact discs

- Do not allow fingerprints, oil or dust to get on the surface of the disc. If the disc is dirty, wipe it off with a soft dry cloth.
- Do not use benzene, thinner, water, record spray, electrostatic-proof chemicals, or silicone-treated cloths to clean discs.
- Always handle discs carefully to prevent damaging the surface; in particular when removing a disc from its case or returning it.
- Do not bend the disc.
- Do not apply heat.
- Do not enlarge the hole in the center of the disc.
- Do not write on the label (printed side) with a hard-tipped implement such as a pencil or ball point pen.

- Condensation will form if a disc is brought into a warm area from a colder one, such as outdoors in winter. Do not attempt to dry the disc with a hair dryer, etc.

2. Precaution on storage

- After playing a disc, always unload it from player.
- Always store the compact disc in the jewel case, protecting from dirt or damage.
- Do not place discs in the following areas:
 - a) Areas exposed to direct sunlight for a considerable time.
 - b) Areas subject to accumulation of dust or high humidity.
 - c) Areas affected by heat from indoor heaters, etc.

CDS LEFT IN PLAYER

If you find you left cd's in the player and the remote has been disconnected. Merely plug into power turn on and use the OP / CL buttons on the player.

SPECIFICATIONS

GENERAL

| | | | |
|---------------------------|---|---|-------------------|
| Type: | Twin mechanism compact disc player with wired controller. | | |
| Disc type: | Standard compact discs (5 in / 12cm and 3in/8cm discs) | | |
| Dimensions: | Player unit: | 19"(W) x 3 15/32" (H) x 9 55/64" (D) | |
| | | 482mm (W) x 88mm (H) x 264mm (D) (without feet) | |
| Control unit: | 19"(W) x 5 3/4" (H) x 1 1/2" (D) | | |
| | | 482mm (W) x 132mm (H) x 74mm (D) (without feet) | |
| Installation: | 19-inch rack mountable | | |
| | Player unit: | 2U / 2 rack spaces | |
| | Control unit: | 3U / 3 rack spaces | |
| Weight: | Player unit: | 11 lbs. / 5 kgs | |
| | Control unit: | 4.5 lbs. / 2 kg | |
| Power supply: | 115/230V AC, 50/60Hz | | |
| Power consumption: | 25W | | |
| Environmental conditions: | Operational temperature: | 5 to 35°C | (41 to 95°F) |
| | Operational humidity: | 25 to 85% | (no condensation) |
| | Storage temperature: | -20 to 60°C | (4 to 14°F) |
| Accessories: | Connecting cord (2 sets for left and right channels) | | |
| | Control cord (1.8m / 6 feet) | | |

AUDIO SECTION

| | |
|------------------------------|---------------------------|
| Quantization: | 16 bit linear per channel |
| Sampling rate: | 44.1 kHz at normal pitch |
| Over sampling rate: | 8 times |
| D/A conversion | 16 bit |
| Frequency response: | 10 to .20000 Hz |
| Total harmonic distortion:* | 0.01% |
| Signal to noise ratio:* | 94 dB |
| Channel separation:* | 86 dB |
| Output level: | 2.OV +/- 1dB |
| Load impedance: | 47 kohm or more |
| * with 20KHz low pass filter | |

FUNCTIONS

| | |
|------------------|-----------------------------|
| Variable pitch: | +/-12% or more |
| Search accuracy: | 1/75 sec. (1 subcode frame) |

Specifications and design are subject to change without notice for purpose of improvement.

American DJ® AUDIO World Headquarters:
4295 Charter Street
Los Angeles, CA 90058 USA
Tel: 323-582-2650
Fax: 323-582-2610

Web: www.americandj.com
E-mail: info@american.com